

# The Influence of Store Image, Service Quality, Private Label Brand Image, Perceived Risk, and Price Consciousness on Purchase Intention

**Meta Andriani**

Indonesia Banking School

[meta.andriani@ibs.ac.id](mailto:meta.andriani@ibs.ac.id)

## Abstract

Previous study found supporting evidence of several factors affecting purchase intention in retail environment. However, there is still few that focus on the private label brand (PLB) despite of the importance of the products for the convenience store business. This study aims to find the direct effects of store image and service quality on brand image and purchase intention for a private label brand (PLB) in the context of convenience store. In addition, it also aims to confirm the factors that directly influence purchase intention of consumers. Two hundred and seven respondents were investigated using nonprobability sampling technique (purposive sampling). The analyses employed Structural Equation Modelling techniques and results indicate that store the image and private label brand image has a direct positive impact on purchase intention. The findings also confirmed that service quality has a direct positive effect on private label brand (PLB) image. Surprisingly, service quality has no direct influence on purchase intention, but have indirect influence through private label brand (PLB) image.

**Keywords:** Perceived Risk, Purchase Intention, Private Label Brand, Price Consciousness, Service quality, Store image.

*Beberapa studi di lingkungan ritel menemukan bukti yang mendukung dari beberapa faktor yang mempengaruhi niat beli. Namun, masih ada beberapa yang berfokus pada label merek pribadi (PLB) sebagai hal penting bagi produk untuk bisnis toko kebutuhan sehari-hari. Penelitian ini bertujuan untuk menemukan efek langsung dari citra toko dan kualitas pelayanan terhadap citra merek dan niat beli untuk label merek pribadi (PLB) pada toko kebutuhan sehari-hari. Selain itu, juga bertujuan untuk mengkonfirmasi faktor-faktor yang secara langsung mempengaruhi niat beli konsumen. Dua ratus tujuh responden diteliti dengan menggunakan teknik sampling nonprobability (purposive sampling). Analisis*

*menggunakan teknik Structural Equation Modelling dan hasilnya menunjukkan bahwa citra toko dan citra label merek pribadi memiliki dampak positif langsung pada niat beli. Temuan juga menegaskan bahwa kualitas pelayanan memiliki efek positif langsung pada citra label merek pribadi (PLB). Anehnya, kualitas pelayanan tidak memiliki pengaruh langsung terhadap niat beli, tapi memiliki pengaruh tidak langsung melalui citra label merek pribadi (PLB).*

**Kata kunci:** Risiko Persepsi, Niat Pembelian, Label Merek Pribadi, Harga Kesadaran, Kualitas Pelayanan, Citra Toko.

## **Background**

The retail business in Indonesia grows rapidly from year to year. It is evident from the many traditional retail businesses that transform their concept into a modern retail business as well as the emergence of new modern retail business. According to data obtained from Business Monitor International (BMI), traditional retail growth estimates around 77% of total retail sales in 2012. The presence of modern retail growth has eroded the traditional retail market share in recent years, because they are capable of providing more services either to consumers by providing what the consumer wants, for example by providing a diverse product variations with a comfortable, good quality and competitive prices. The growth of the middle class and lifestyle changes spurred the growth of convenience store business, where this segment tends to prioritize practicality, and fast service to their needs, especially the need for food and beverage.

The growth of retail business in Indonesia from year to year is quite, it is evident from the many traditional retail businesses that transform their concept into a modern retail business as well as the emergence of new modern retail business. According to data obtained from Business Monitor International (BMI), traditional retail growth is estimated around 77% of total retail sales in 2012. The presence of modern retail growth has eroded the traditional retail market share in recent years, because they are capable of providing more services either to consumers by providing what the consumer wants, for example by providing a diverse product variations with a comfortable, good quality and competitive prices. The growth of the middle class and lifestyle changes spur the growth of convenience store business, where this segment tends to prioritize practicality, and fast service to their needs, especially the need for food and beverage.

Previous research on private label brands are divided into two categories, the first category on the relationship between private label brands and national brand promotion in the journal Sloan Management Review (Hoch, 1996) and the Journal of Retailing

(Garretson, 2002), showing the differences and similarities between the two concepts. The second category, explain the factors that influence consumer behavior towards the consumption of private label products (Baltas, 2003; Batra and Sinha, 2000; Burton (1998), Richardson (1996)). The study looks at the second category is focused on product factor level and consumer level. Product level describes the product category (Delvecchio, 2001) and the perceived risk (Semeijn, 2004), while the consumer level to explain the price consciousness as quoted in Australian Marketing Journal (Burger and Schott, 1972; Jin and shuh, 2005; Sinha and Batra , 1999) and its relationship with extrinsic factors (Delvecchio, 2001; Batra and Sinha, 2000). Although previous studies rarely to discuss factors store level, currently these factors become important (Semeijn, 2004) Collins-Dodd and Lindley (2003) and Vahie and Paswan (2006), this study shows that when consumers are not familiar with private label brand, they rely on their perceptions of the image of the store (store image) to decide to buy a private label product.

Previous research on private label brands are divided into two categories, the first category on the relationship between private label brands and national brand promotion in the journal Sloan Management Review (Hoch, 1996) and the Journal of Retailing (Garretson, 2002), showing the differences and similarities between the two concepts. The second category, explain the factors that influence consumer behavior towards the consumption of private label products (Baltas, 2003; Batra and Sinha, 2000; Burton (1998), Richardson (1996)). The study looks at the second category is focused on product factor level and consumer level. Product level describes the product category (Delvecchio, 2001) and the perceived risk (Semeijn, 2004), while the consumer level explain the price consciousness as quoted in Australian Marketing Journal (Burger and Schott, 1972; Jin and shuh, 2005; Sinha and Batra , 1999) and its relationship with extrinsic factors (Delvecchio, 2001; Batra and Sinha, 2000). Although previous studies rarely discuss store level factors, these factors currently become important (Semeijn, 2004) Collins-Dodd and Lindley (2003) and Vahie and Paswan (2006), this study shows that when consumers are not familiar with private label brand, they rely on their perceptions of store image to decide to buy a private label product.

Service quality is also an important factor in consumer buying decision process (Carrilat, FA., Jaramilo. F., Mulki, J.P. 2009). According to Ailawadi and Keller (2004), retailers have to establish their brand image by creating something unique to the quality of its services. Therefore, this study aims to describe the direct impact of two variables, namely store image and service quality in a brand image and the purchase intention in the private label brand. The study also aims to look at the factors that influence directly the interest to buy (purchase intention) consumers.

This study aims to find out if there is any influence of store image on the image of private label brands (PLB image) and the purchase intention in convenience stores 7-Eleven, and then aims to know if there is any influence of service quality to the image of private label brands (PLB image) at the 7-Eleven convenience stores as well as to determine the factors that influence directly the consumer's purchase intention.

### Theoretical Framework

In this study, researchers replicate a study that was taken from the Australian Marketing Journal, entitled The Effect of Store Image and Service Quality on Brand Image and Purchase Intention for Private Label Brands. This journal is the result of research Wu, Paul CS; Yen, Gary Yeong-Yuh; Hsiao, Chieh-Ru (2011) and following a research model that was built as a reference of this study:

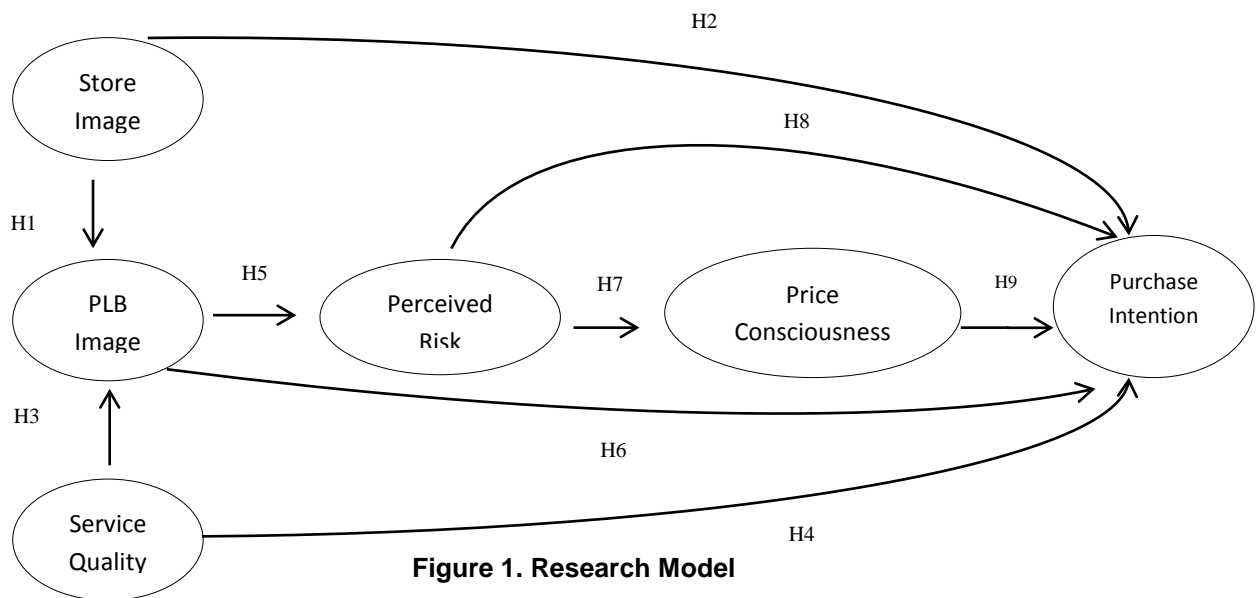

**Figure 1. Research Model**  
**Source : Paul Wu., et al (2011)**

### *Impact of Store Image to the image of Private Label Brand (PLB Image) and Interest Purchase (Purchase Intention)*

Factors store image used by consumers to decide to buy a private label brand (Ailawadi and Keller, 2004; Collins-Dodd and Lindley, 2003). When the consumer perception of the image height shop, will form a positive impact on a brand. The image of the store has a direct positive relationship with interest in buying the private label brand. The more positive the image generated by the store, the higher the interest in buying that will be generated Dodds., (1991) and Grewal. (1998) Based on the above relationship, it can be collated hypothesis as follows:

H1: The image of the store (store image) has a positive influence on the image of the private label brand (PLB image).

H2: The image of the store (store image) have a positive influence by interest in buying private label products.

Quality of service is one important factor in consumer decision process. According to Brady, (2002), there is a relationship between service quality and behavioral intention. Good service will generate behavioral intention positive and increasing buying interest from consumers so that eventually the consumer will increase the frequency of visits to the store (Carriliat, 2009; Cronin and Taylor, 1992; Fornell, 1992; Szymanski and Henard, 2001; Zeithaml., 1996) , It indicates when a store provides a good service, customer satisfaction with the store increases, and purchasing decisions towards private label products will increase as well. Based on the above relationship, it can be collated hypothesis as follows:

H3: Quality of Services (service quality) have a positive influence on the image of Private Label Brand (PLB image).

H4: Quality of Services (service quality) has a positive influence on interest in buying (purchase intention).Dampak Citra *Private Label Brand* (PLB *Image*) terhadap Persepsi Risiko (*Perceived Risk*) dan Minat Membeli (*Purchase Intention*)

Private labels have limitations in terms of promotion when compared to other products. So the brand image factor and the price becomes a reference for consumers in evaluating private label brand and reduce the risk (perceived risk) of existing products (Shimp and Bearden, 1982; Perry and Perry, 1976). When consumers perceive the brand image well, then they will decrease the risk perception (Cox, 1962; Kotler and Keller, 2008; Roselius, 1972). Brands that have a good perception consumers will have a positive attitude toward the brand and ultimately the desire to buy their products will also be high (Kamins and Marks, 1991). Based on the above relationship, it can be collated hypothesis as follows:

H5: The better the consumers' perception of the image of private label brand (PLB image), the lower the perception of risk (perceived risk) of consumers towards private label products.

H6: The better the consumers' perception of the image of private label brand (PLB image), the higher the interest in buying consumer (purchase intention).

#### *Impact of Risk Perception (Perceived Risk) to Price Consciousness and Interest Purchase (Purchase Intention) Private Label*

Consumers tend to avoid risk (Bauer, 1960), meaning that when the consumer perceptions of the emergence of risks that would affect the interest to buy, then the

consumer will decide to reduce their purchases, so then the perception of risk is an important factor in the purchase of private label products (Bettman, 1974) , However, if a consumer facing private label products as a brand they do not know, it will lower the price consciousness and reduce their purchases (Tseng and Hwang, 2003). Thus, they will not be motivated to go back to buy products that are cheaper and tend to buy products with other brands (national brand). Based on the above relationship, it can be collated hypothesis as follows:

H7: Perceptions of risk (perceived risk) against private label products have a negative effect for the price consciousness.

H8: Perceived risk (perceived risk) against private label products have a negative effect for the interest to buy (purchase intention) private label products. *Dampak Price Consciousness terhadap Minat Membeli (Purchase Intention) Produk Private Label*

Price consciousness is high tend to make consumers to purchase products that cost (Moore and Carpenter, 2006). Prices are cheap is one important factor to attract consumers to buy private label products. Based on the above relationship, it can be collated hypothesis as follows:

H9: The increase in price consciousness will cause interest to buy (purchase intention) against private label products increased.

#### *Method of Data Collection*

*To validate the hypothesis and answering the research, quantitative study was conducted using* questionnaire distributed to respondents, including being distributed to the subject at 7-Eleven outlets. Population and sample in this research are everyone knows that 7-Eleven has a private label products sold in their stores. The sample using purposive and non-probability sampling where the sample is selected based on an assessment of researchers that it is the best sample for being research sample. Total 239 respondents surveys were gathered, of which 32 questionnaires were un-valid so it cannot be processed further.

This study uses a scale of 1-6 with the Likert scale interval. Answer to every items of instrument that uses Likert Scale has value of very positive to very negative to the form of words among others: Strongly Disagree (SS), Agree (S), Somewhat Agree (USA), Somewhat Disagree (ATS), disagree (TS) and Strongly disagree (STS). Analysis and testing models in this study is conducted by using the tools of statistical program LISREL

8.87 (Linear Structural Relations). SEM analysis phase in this research is done by using the "two step approach" which begins with the analysis and testing of the measurement model and then perform the analysis and testing of structural models (Ghozali, 2005):

## Research Result

Below table represents the loading factor value, which indicates the level of validity of the questionnaire that can be declared invalid. All loading factor values are above 0.50. It shows that each of the questions posed in the questionnaire can measure every latent variable or construct well. The level of reliability that is expressed by Cronbach's Alpha showed scores above 0.60 indicating that the questions have a high degree of reliability that can be used as a measuring tool in the research.

**Table 1. Validity and Reliability Test**

<b>Construct</b>	<b>Indicator</b>	<b>Loading Factor</b>	<b>Information</b>	<b>Cronbach's Alpha</b>	<b>Information</b>
<i>Store Image</i>	SI1	0.575	Valid	0.771	Reliable
	SI2	0.728	Valid		
	SI3	0.753	Valid		
	SI4	0.697	Valid		
	SI5	0.596	Valid		
	SI6	0.768	Valid		
<i>Services Quality</i>	SQ1	0.923	Valid	0.898	Reliable
	SQ2	0.923	Valid		
	SQ3	0.974	Valid		
	SQ4	0.974	Valid		
	SQ5	0.935	Valid		
	SQ6	0.935	Valid		
<i>PLB Image</i>	PLB1	0.822	Valid	0.864	Reliable
	PLB2	0.862	Valid		
	PLB3	0.735	Valid		
	PLB4	0.854	Valid		
	PLB5	0.854	Valid		
<b>Construct</b>	<b>Indicator</b>	<b>Loading Factor</b>	<b>Information</b>	<b>Cronbach's Alpha</b>	<b>Information</b>
<i>Perceived Risk</i>	PR1	0.875	Valid	0.822	Reliable
	PR2	0.840	Valid		
	PR3	0.713	Valid		
	PR4	0.616	Valid		
	PR5	0.955	Valid		
	PR6	0.924	Valid		
	PR7	0.932	Valid		

<i>Price Consciousness</i>	PR8	0.945	Valid	0.775	Reliable
	PR9	0.806	Valid		
	PC1	0.619	Valid		
	PC2	0.851	Valid		
	PC3	0.850	Valid		
<i>Purchase Intention</i>	PC4	0.762	Valid	0.846	Reliable
	PI1	0.931	Valid		
	PI2	0.931	Valid		

Source: Data Processed (2012)

Pictures of the model t-values below displays the track diagram with the complete model numbers that indicate the value t of each number associated estimation. Value-t < 1.96 ( $\alpha = 5\%$ ) is shown in red and shows that an estimate is not significantly related to or equal to zero.

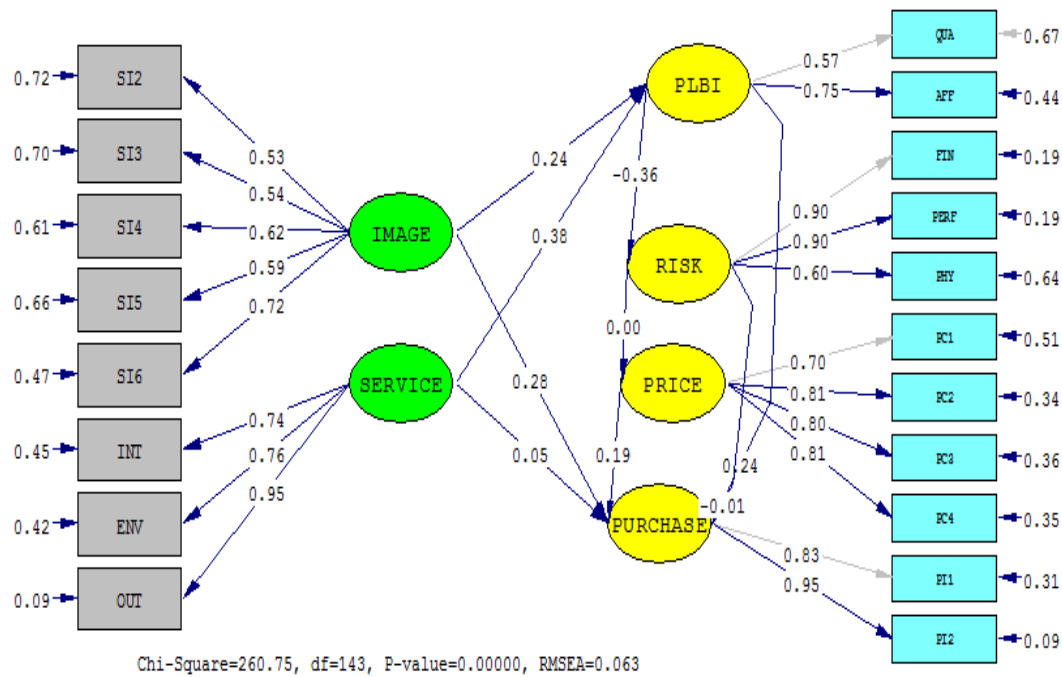

**Figure 2. Structural Model – estimates**

**Source: Data Processed (2012)**



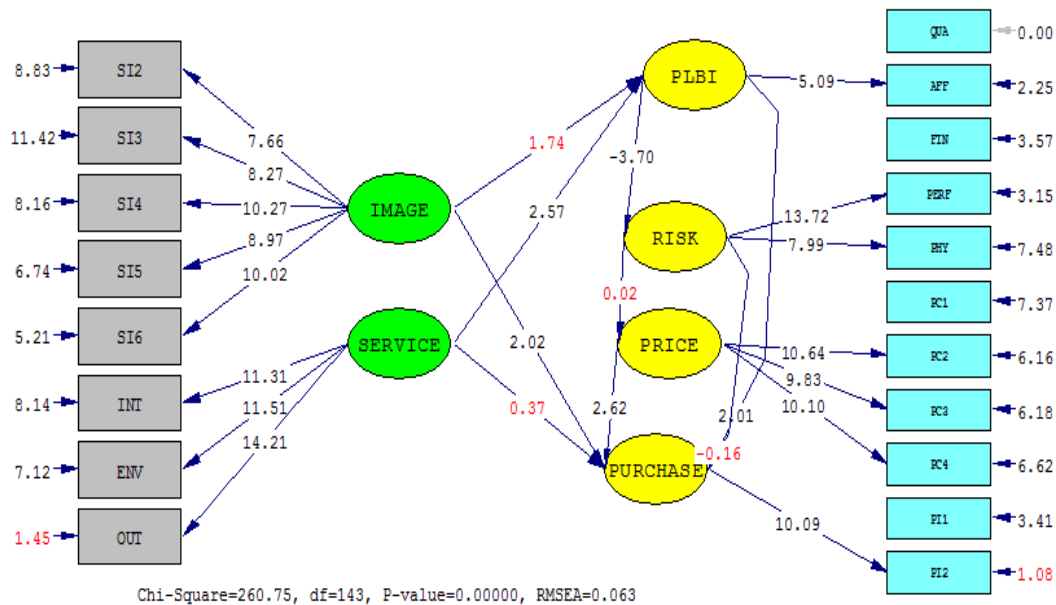

**Figure 3 – Structural Model t-values**

Sources: Data processed (2012)

From the above picture, it can be explained that:

Store image of 7-Eleven that had been captured by the respondent was not strong enough to improve the image of private label brands. Store image is still perceived as a store that has a reasonable price, good quality and have products that are economical compared to the impression of the main product that is owned by 7-Eleven (the image of private label products). Then, from the 7-Eleven store image, the purchase intention will be higher to buy private label products 7-Eleven. When it is viewed from the functional aspects, store image is associated with products sold in stores, price and store layout. While the psychological aspect, store image is related to the value of those stores as a result of perception that is raised by the consumer, friendly feelings that are created by the shop staff, feeling of belonging (sense of belonging) to the store, as well as the values obtained from the design store, symbols, colors and store displays. In this study, the service quality has an influence on the image of private label brands, but the service quality does not have an influence on consumer's purchase intention against private label products brand. Consumer convenience stores like 7-Eleven is a consumer serve themselves when shopping (self-service), so the factor of service quality provided by the store through its staff does not affect the interest of consumers to buy.

The better the image or consumer perceptions of private label products of 7-Eleven, the lower their concern over the risk that will happen when they consume the product 7-Eleven. When consumers are faced with the reality that they do not recognize

the product, consumers will tend to hesitate to buy the product. Then, the better the image or perception of private label products of 7-Eleven, the higher the interest of the consumer to buy the product. It proves that a good image is very important in influencing consumer buying interest.

On the other hand, the perceived risk has no effect on price consciousness. It is seen that consumers do not care about the risks that would occur if they consume the product 7-Eleven, but they are more concerned with the price of a cheap product. This could happen because as much as 63% of respondents in this study were students, which in this group have a low income.

Perceived risk has no influence on purchase intention. The risks that arise when consumers do not feel familiar with 7-Eleven products, such as financial risk factors, performance and physical risks does not directly affect the consumer's purchase intention of 7-Eleven's product. Interest to buy again the products at 7-Eleven stores is not directly affected by the perception of the risk of loss that will be experienced by respondents when purchasing the product 7-Eleven. Price consciousness has an influence on buying interest. 7-Eleven consumers are very concerned with the price factor. It is because as much as 55% of respondents in this study is in the age range 21-25 years 7-Eleven is the target consumer. To maintain this, then at an affordable price on the product 7-Eleven will be the hallmarks of 7-Eleven convenience stores on the other.

After conducting Structural Equation Modeling (SEM) analysis and see the causal relationship of the research model that is previously set, it appears that the perceived risk of latent variables has no effect on price consciousness and purchase intention. It is then proposed to simplify the model by removing the perceived risk variables. Here are the results of Lisrel 8.87 processing by eliminating the perceived risk of latent variables:

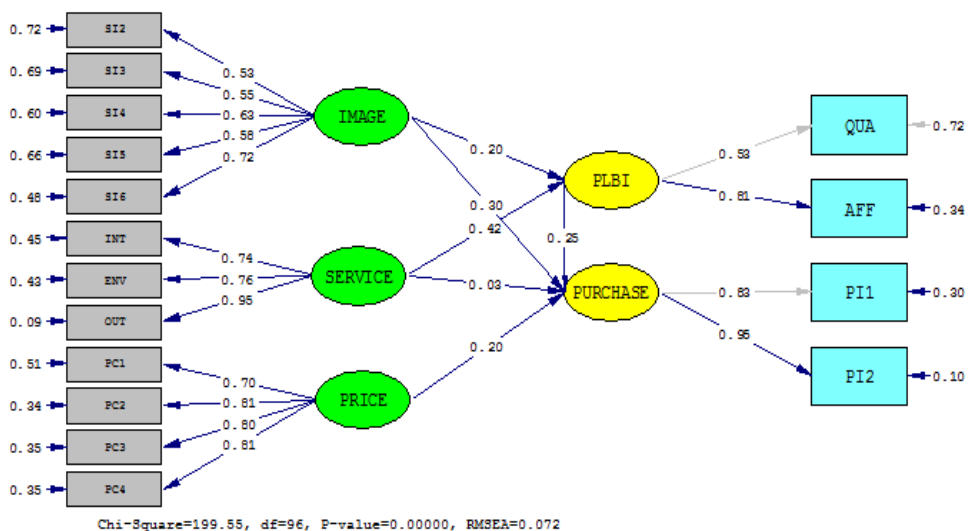

**Figure 4: Structural models of alternative models – estimates**  
Source: Data processed (2012)

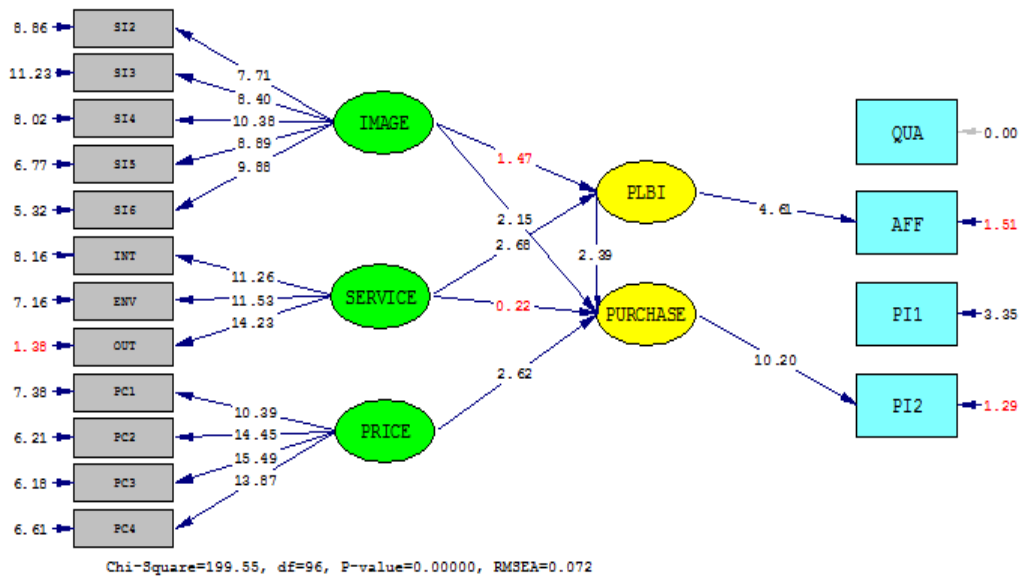

**Figure 5: Structural Model of Alternative Model – t-values**

Source : data processed (2012)

Based on the above results, it can be seen that there is no significant change of the result between the hypothesized latent variables compared to the previous model, the explanation as shown in the table below:

- Store image does not have positive influence on PLB image, however, it will have positive influence on purchase intention.
- Service quality has significant influence on PLB image but it does not influence significantly on purchase intention.
- PLB image has significant influence on purchase intention.
- Price consciousness has positive influence on purchase intention.

Research model that eliminate the perceived risk level indicates better match, although the absolute GoF dimension is RMSEA showing higher values. GoF size is incremental between the two models show that the value of GoF model without perceived risk shows higher yields.

**Table 2. Goodness of Fit (GoF) Comparison Initial Model and Alternative Model**

<i>GoF Dimension</i>	<i>Match Target</i>	
	<i>Initial Model</i>	<i>Alternative Model</i>
<i>Estimated Non-centrality Parameter (NCP)</i>	117.75	103.55
<i>Root Mean Square Error of Approximation (RMSEA)</i>	0.063	0.072
<i>Model AIC</i>	354.75	279.55
<i>Model CAIC</i>	558.38	452.86

**GoF Dimension****Match Target****Initial Model****Alternative Model**

<i>GoF Dimension</i>	<i>Initial Model</i>	<i>Alternative Model</i>
<i>Normed Fit Index (NFI)</i>	0.9	0.91
<i>Non-Normed Fit Index (NNFI)</i>	0.94	0.94
<i>Parsimony Normed Fit Index (PNFI)</i>	0.75	0.73
<i>Comparative Fit Index (CFI)</i>	0.95	0.95
<i>Incremental Fit Index (IFI)</i>	0.95	0.95
<i>Relative Fit Index (RFI)</i>	0.88	0.89
<i>Goodness of Fit Index (GFI)</i>	0.86	0.87
<i>Adjusted Goodness of Fit Index (AGFI)</i>	0.82	0.82
<i>Parsimony Goodness of Fit Index (PGFI)</i>	0.65	0.61

Source: Data Processed (2012)

## Conclusion

In general, there is only one variable that affect private label brands image (PLB image) that is service quality with amount of 0,51. Overall, there are 3 (three) variables that affect the purchase intention, they are the image of store image, PLB image and price consciousness. Nevertheless, among these three variables, store image plays an important role in the decision related to purchase intention. The store image has the greatest influence in the amount of 0.240 followed by PLB image that has influence in the amount of 0.232, and price consciousness in the amount of 0.205.

Store image variable does not have significant direct influence on the image of private label brand (PLB image), so we can say the data does not support H1 or in other words if store image of 7-Eleven increase, it will not affect image of PLB image of 7-Eleven. However, the study found that store image has a direct significant influence on the purchase intention, so we can say the data supports H2 or in other words if the store image of 7-Eleven increases, it will increase as well as purchase intention of 7-Eleven product.

Service quality variable has significant direct influence on the image of private label brand (PLB image), so we can say the data supports the H3 or in other words if the service quality of 7-Eleven increases, it will also increase the image of private label brand (PLB image). Service quality does not have significant direct influence on purchase intention, so we can say the data des not support H4. In other words, if service quality of 7-Eleven increase, it will not affect purchase intention to buy 7-Eleven products.

Private Label Brand image (PLB image) has significant direct influence on the perceived risk, so we can say the data supports the H5. In other words, if the image of the private label brand (PLB image) increases, the lower perceived risk of consumers towards

products of 7-Eleven will be. It also validated the direct influence of this construct on the purchase intention, so we can say the data supports H6. In other words, if the image of the private label brand (PLB image) increases, purchase intention of consumers towards products of 7-Eleven will increase as well.

Perceived risk variable does not have significant direct influence on the price consciousness variable, so we can say the data does not support H7. In other words if the perceived risk increases, it will not affect the price consciousness of consumers. Perceived risk variable does not have significant direct influence on purchase intention variable, so we can say the data does not support the H8. In other words if the perceived risk of customers increases, it will not affect the purchase intention of consumers.

Price consciousness variable has significant direct influence on the purchase intention variable, so we can say the data supports H9. In other words if the price increases, purchase intention of consumers towards products of 7-Eleven will also increase. Finally, although the results of structural equation did not change between the initial model and an alternative model but, when seen from the good of fit (GoF), an alternative model is better than the early models.

### **Managerial Implication and Recommendation**

There are several implications of this study to the industry. First is to improve the private label image of products through store image, it needs a special strategy to educate the customers who come by strengthening the image that the products 7-Eleven is a unique product and are not sold elsewhere. 7-Eleven should be able to maintain its differences in terms of products, where these products are not sold in other retail stores while it is maintaining quality of product in order to remain well and it can perform pricing strategies that can improve consumer perception that prices at the 7-Eleven affordable and have economic value that consumers are willing to buy the product 7-Eleven. Another suggestion is to train the staff on service excellent so that it can serve consumer of 7-Eleven well.

Store settings such as attractive store displays, is very factor important for convinience store. It should be strengthened with neatness and cleanliness, the easily visible products, accessible and searchable, as well as the storage location of the right product, and secured attractive.

On the feature of products, the brand should improve the quality of private label products with innovation in terms of both taste and variants as well as maintaining the

quality of private label products by monitoring the freshness of its products, such as monitoring the expiration date and the preventing of the product from damage.

The management should prioritize their marketing communications and promotions to enhance the brand image of the product in 7-Eleven. Marketing communications in the form of advertising, for example, can help to increase the brand consumers' awareness of the product of 7-Eleven. It might also work to promote through bundling package for foods and beverages with tester.

### *Reccomendation*

This study is a replication of previous studies, it is expected that further studies looking at the relationship between quality service and perceived risk which has not been explained how the relationship between the variables. This is done so that the findings become more varied. Previous studies see the relationship among variable store image, service quality, brand image and the purchase intention on private label products in specialty stores. Meanwhile, this study was conducted on a convenience store, expected future studies can test it against other types of retails such as supermarkets, which usually has a more variants of private label products. The development of retail business in Indonesia is highly developed in the last few years, it is expected that further research will test it on other retail store brands, especially brands, new to the retail market in Indonesia.

### **Reference**

- Ailawadi, K.L., Keller, K.L., (2004). Understanding Retail Branding : Conceptual Insights and Research Priorities. *Journal of Consumer Affairs* 30 (2), 421-443.
- Anderson, W.T. (1972). 'Convenience Orientation and Consumption Behaviour', *Journal of Retailing* 48(Fall): 49–71.
- Anjani, Okki Rianayu. (2012). *Analisis Pengaruh Marketing Mix Activity Terhadap Brand Equity dan Media Credibility : Studi Kasus Majalah Wanita Femina*. Jakarta, Magister Manajemen Universitas Indonesia, "Tesis".
- Baltas, C., (2003). A Combined Segmentation and Demand Model for Store Brands. *European Journal of Marketing* 37 (10), 1499-1513
- Batra.R., Sinha, I., (2000). Consumer-Level Factors Moderating The Success of Private Label Brands. *Journal or Retailing* 76 (2). 175-191.
- Bauer, R.A., (1960). Consumer Behavior as Risk Taking. In : Hancock, R.S. (Ed). *Dynamic Marketing for a Changing World*. American Marketing Association, Chicago, pp. 389-398.

- Berman, Berry and Joel R. Evans. (2004). *Retail Management : A Strategic Approach*. Pearson : Prentice Hall.
- Bianchi, Constanza. (2009). Investigating Consumer Expectations of Convenience Store Attributes in Emerging Markets : Evidence in Chile. *Journal of International Consumer Marketing* 21(4).
- Burger, P.C., Schott, B., (1972). Can Private Brand Buyers Be Identified. *Journal of Marketing Research* 9, 219-222.
- Burton. S., Lichtenstein. D.R., Netemeyer, R.G., Garretson, J.A., (1998). A Scale for Measuring Attitude Toward Private Label Products and Examination of Its Psychological and Behavioral Correlates. *Journal of The Academy of Marketing Science* 26 (4), 293-306.
- Carrillat, F. A., Jaramilo. F., Mulki. J.P., (2009). Examining The Impact of Service Quality : A Meta-Analysis of Empirical Evidence. *Journal of Marketing Theory and Practice* 17 (2), 95-110.
- Collins-Dodd, C., Lindley, T., (2003). Store Brand and Retail Differentiation : The Influence of Store Image and Store Brand Attitude on Store Own Brand Perceptions. *Journal of Retailing and Consumer Services* 10, 345-352.
- Cronin. J.J., Taylor. S.A., (1992). Measuring Service Quality : A Re-examination and Extension. *Journal of Marketing*. 56 (3). 55-68.
- Dabholkar, P.A., Bobbitt, L.M. and Lee, E-J. (2003). Understanding consumer motivation and behavior related to self-scanning in retailing: implications for strategy and research on technology-based self-service. *International Journal of Service Industry Management*, Vol. 14 No. 1, pp. 59-95.
- Darandono. (2012, Oktober 13). "2012, Bisnis Ritel di Indonesia Kian Menjanjikan". November 10, 2012. <http://swa.co.id/business-strategy/marketing/2012-bisnis-ritel-di-indonesia-kian-menjanjikan>.
- DelVecchio, D,. (2001). Consumer Perceptions of Private Label Quality : The Role of Product Category Characteristics and Consumer Use of Heuristics. *Journal Retailing and Consumer Services* 8 (5). 239-249.
- Fitria, Diany. (2012). *Analisis Ekspektasi Konsumen Terhadap Atribut-Atribut Convenience Store : Studi Kasus Convenience Store 7-Eleven Jakarta*. Jakarta, Magister Manajemen Universitas Indonesia, "Tesis".
- Fornell, C.R., (1992). A National Customer Satisfaction Barometer : The Swedish Experience. *Journal of Marketing*. 56 (1).6-21.
- Garretson, J. A, Fisher. D. Burton. S. (2002). Antecedents of Private Label Attitude and National Brand Promotion Attitude : Similarities and Differences. *Journal of Retailing* 78 (2). 91-99.

- Goldrick, J.Peter. (1990). *Retail Marketing*. McGraw Hill Book Company.
- Ghozali, Imam. (2005). *Structural Equation Modelling : Teori, Konsep, dan Aplikasi dengan Program LISREL 8.54*. Semarang. Badan Penerbit Universitas Diponegoro.
- Ghozali, Imam. (2007). *Aplikasi Analisis Multivariate dengan Program SPSS, Hal 42*. Semarang: Universitas Diponegoro.
- Grewal, D., Krishnan. R., Baker, J., Borin, N., (1998). The Effect of Store Name, Brand Name and Price Discounts on Consumers' Evaluations and Purchase Intention. *Journal of Retailing* 74 (3). 331-352
- Hair,j. F., Black, B, Babin, H., Anderson, R. E., & Tatham, R. L, (2010). *Multivariate Data Analysis: A Global Perspective*. New Jersey : Pearsons Education Inc.
- Hoch, S.J., (1996). How Should National Brands Think About Private Labels?. *Sloan Management Review*. 37(2). 89-102.
- Jasfar, Farida & Kristaung, Robert. (2012). *Sinergi Pemasaran Jasa Ritel*. Jakarta. Penerbit Universitas Trisakti.
- Kelloway, Kevin (1998;20), *Using Lisrel for Structural Equation Modeling*, Sage Publication.
- Kelly et al., (2011). *Handbook of Marketing Scale, Multi Item Measures For Marketing and Consumer Behavior*,. Sage Publication.
- Kotler, Philip, Kevin Lane Keller, (2009), *Marketing Manager*, New Jersey : Prentice Hall
- Listiyani, Aprilia. (2011). *Pengaruh Karakteristik Produk Terhadap Intensi Pembelian Produk Private Label Carrefour*. Jakarta, Magister Manajemen Universitas Indonesia, "Tesis".
- Lovelock, Christopher, Jochen Wirtz. *Services Marketing : People, Technology, Strategy*. (6th edition). Pearson International Edition.
- Malhotra, Naresh. K. (2010). *Marketing Research: An Applied Orientation*. New Jersey: Pearson Educational International.
- Moore, M., Carpenter, F., (2006). The Effect of Price as a Marketplace Cue on Retail Patronage. *Journal of Product and Brand Management* 15(4), 265-271.
- Perry, M., Perry, A., (1976). Service Contract Compared to Warranty as a Means to Reduce Consumer's Risk. *Journal of Retailing* 52 (2), 33-40.
- Rex B. Kline. (2011), *Principles and Practice of Structural Equation Modeling*. The Guilford Press.
- Riley, Jim. (2012). "Ansoff Matrix". [http://www.tutor2u.net/business/strategy/ansoff\\_matrix.htm](http://www.tutor2u.net/business/strategy/ansoff_matrix.htm). 28/11/2012.
- Richardson, P. S., Jain, A.K., Dick, A., (1996). Household Store Brand Proneness : A Framework. *Journal of Retailing* 72 (2). 159-185.



- Seiders, K., Voss, G., Grewal, D. and Godfrey, A. (2005) 'Do Satisfied Customers Buy More? Examining Moderating Influences in a Retailing Context, *Journal of Marketing* 69(4): 26–43.
- Semeijn, J., van Riel, A.C.R., Ambrosini, A.B., (2004). Consumer Evaluations of Store Brands : Effect of Store Image and Product Attributes. *Journal of Retailing and Consumer Services* 11(4), 247-258.
- Shimp, T.A., Bearden. W., (1982). Warranty and Other Extrinsic Cue Effects on Consumer Risk Perceptions. *Journal of Consumer Research* 9 (1). 38-46,
- Sihombing, Aldo. (2010). *Analisis Persepsi Konsumen Terhadap Bauran Pemasaran dari Convenience Store : Studi Kasus Toko 7-Eleven di Jakarta*. Jakarta, Magister Manajemen Universitas Indonesia, "Tesis".
- Sinha, I., Batra, R., (1999). The Effect of Consumer Price Consciousness on Private Label Purchase. *International Journal of Research in Marketing* 16 (3), 237-251
- Solomon, Michael R. (2009). *Consumer Behavior : Buying, Having and Being (8th edition)*. New Jersey: Pearson Education Inc.
- Sopiah & Syihabudhin. (2008). *Manajemen Bisnis Ritel*. Yogyakarta: Penerbit ANDI.
- Sumarwan, Ujang., et. al., (2011). *Riset Pemasaran dan Konsumen : Panduan Riset dan Kajian : Kepuasan, Perilaku Pembelian, Gaya Hidup, Loyalitas, dan Persespi Risiko*. Bogor. Penerbit IPB Press.
- Sumintapura, Rosita Jusuf. (2002). Analisis Persepsi Konsumen Terhadap Produk Private Label : Studi Kasus Hero dan Makro. Jakarta, Magister Manajemen Universitas Indonesia, "Tesis".
- Szymanski, D.M., Henard, D.H., (2001). Customer Satisfaction : A Meta-Analysis of The Empirical Evidence. *Journal of The Academy of Marketing Science*. 29 (1). 16-35.
- Tseng, Y.M., Hwng, F.S., (2003). The Mediate Effect of Price Consciousness on Purchasing Private Brand : The Application of Path Analysis Model. *Chiao Da Management Review* 23 (1). 151-182.
- Utami, Christina Whidya. (2010). *Manajemen Ritel : Strategi dan Implementasi Ritel Modern*. Jakarta: Salemba Empat.
- Vahie, Archana ; Paswan, Audesh. (2006). Private Label Brand Image : Its Relationship With Store Image and National Brand. *International Journal of Retail & Distribution Management*. 34.
- Wijanto, Setyo Hari. (2008). *Structural Equation Modeling Dengan Lisrel 8.8, Konsep dan Aplikasi*. Yogyakarta: Graha Ilmu.
- Wu, Paul CS ; Yen, Gary Yeong-Yuh ; Hsiao, Chieh-Ru. (2011). The Effect of Store Image and Service Quality on Brand Image and Purchase Intention for Private Label Brands. *Australian Marketing Journals*. 30-39.

- Yamin, Sofyan & Kurniawan, Heri. (2009). *Structural Equation Modeling, Teknik Analisis Data Kuesioner dengan Lisrel dan PLS*. Jakarta. Salemba Infotek.
- Zeithaml Valerie A, Bitner Mary Jo, Gremler Dwayne D, (2009). *Services Marketing : Integrating Customer Focus Across the Firm*, 5th edition. New York: McGraw Hill International Edition.